

New Sinus Solution

Innovative safety and convenience

D:O IMPLANT



Crestal Sinus KIT

- Equipped with stop drills in various heights to match different residual bone levels
- For elevations of 3 mm or less, safe and efficient lifting can be achieved with the drill alone
- For elevations of 4 mm or more, or when extensive lifting is required, the hydraulic lifting device provides safety and convenience

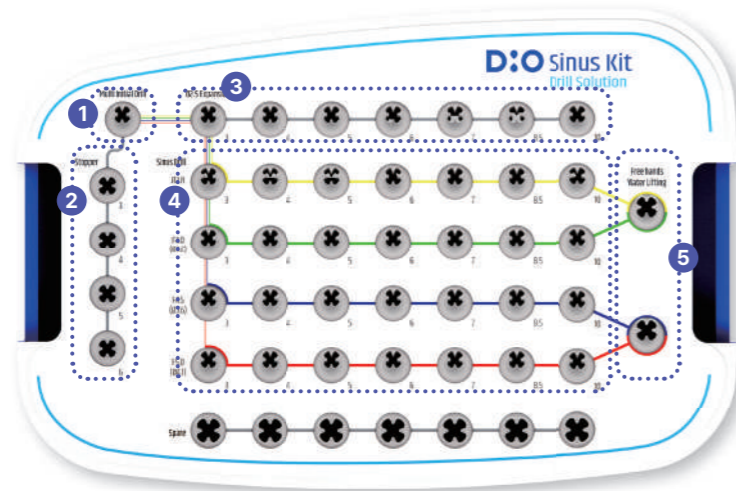

1 Multi Initial ST Drill

- Used for initial drilling hole or to adjust drilling direction
- Designed to prevent slipping on inclined bone surfaces
- Appropriate stopper use considering residual bone height



2 Stopper

- Controls the drilling depth of the Multi Initial ST Drill
- Color-coded and laser-marked for clear identification of length



3 Sinus Expansion Drill

- Enlarges the osteotomy before using the Sinus Lift Drill
- Stop drills of different lengths corresponding to residual bone height



4 Sinus Lift Drill

- Pushes bone chips upward to elevate the sinus membrane
- Protects the sinus membrane during drilling
- Stop drills of different lengths corresponding to residual bone height



5 Water Membrane Lifter

- Hydraulic instrument for sinus elevation procedure
- Securely engages with the drilled hole via clockwise rotation
- Enables convenient hydraulic lifting without additional assistance



Water Membrane Lifter Dummy

- Used to seal the remaining drilled holes when hydraulic lifting is performed on 2 holes or more
- *Sold separately, Not part of the kit components



Sinus Membrane Detach tool

- Designed for crestal sinus membrane detachment
- Slim, rounded design allows safe detachment, even in cases with minimal residual bone
- *Lower tray component



Depth Gauge

- Measures the depth of the drilled hole
- *Lower tray component



Saline Tube

- Connects the water membrane lifter to a syringe for hydraulic elevation
- * Syringe : Sold separately, Not part of the kit components



Steel Bowl

- Used for mixing bone grafts or preparing sterile solutions
- *Lower tray component

✳Example: Residual bone height of 5 mm

Initial drilling

- Use a drill stopper 1-2 mm shorter than the bone height below the maxillary sinus floor, as measured by CBCT
- Recommended speed: 600–1,000 rpm



Expansion drilling

- Drill to the same depth as the initial drilling
- Recommended speed: 600–1,000 rpm



Sinus approach drilling

- Begin with the Ø2.8 mm drill, advance 1mm at a time
- Confirm sinus approach using a depth gauge
- Recommended speed: 600–1,000 rpm

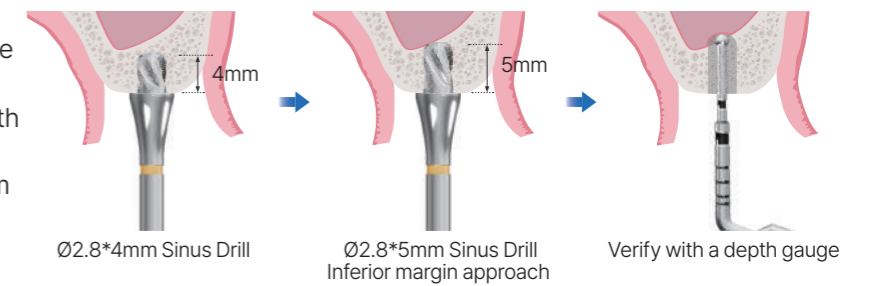

Final sinus drilling

- Drill up to the diameter corresponding to the planned fixture size
- If needed, lift the sinus membrane an additional 1-3 mm
- Recommended speed: 600–1,000 rpm

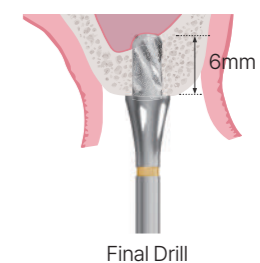

Bone graft and implant placement

- Place the implant while elevate the sinus membrane with the fixture
- Bone grafting may be performed if required.



Implant placement with sinus membrane elevation

Crestal Sinus KIT

- Designed to minimize patient discomfort during crestal sinus elevation procedures
- Equipped with dedicated stopper attachments for precise and convenient depth adjustment
- For elevations of 4 mm or more, or when extensive lifting is required, the hydraulic lifting device provides safety and convenience

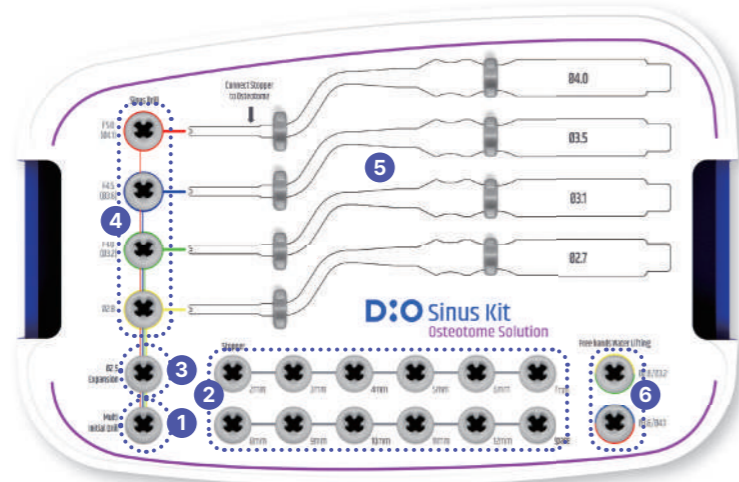

1 Multi Initial ST Drill

- Used for initial drilling hole or to adjust drilling direction
- Designed to prevent slipping on inclined bone surfaces
- Appropriate stopper use considering residual bone height



2 Stopper

- Controls the drilling depth of the Multi Initial ST Drill
- Color-coded and laser-marked for clear identification of length



3 Sinus Expansion ST Drill

- Enlarges the osteotomy before using the Sinus Lift Drill
- Appropriate stopper use considering residual bone height



4 Sinus Lift ST Drill

- Pushes bone chips upward to elevate the sinus membrane
- Protects the sinus membrane during drilling
- Appropriate stopper use considering residual bone height



5 Wave ST Osteotome

- Designed to reduce impact stress transmitted to the patient
- Appropriate stopper use considering residual bone height



6 Water Membrane Lifter

- Hydraulic instrument for sinus elevation procedure
- Securely engages with the drilled hole via clockwise rotation
- Enables convenient hydraulic lifting without additional assistance



Water Membrane Lifter Dummy

- Used to seal the remaining drilled holes when hydraulic lifting is performed on 2 holes or more
- *Sold separately, Not part of the kit components



Depth Gauge

- Measures the depth of the drilled hole
- *Lower tray component



Sinus Membrane Detach tool

- Designed for crestal sinus membrane detachment
- Slim, rounded design allows safe detachment, even in cases with minimal residual bone
- *Lower tray component



Steel Bowl

- Used for mixing bone grafts or preparing sterile solutions
- *Lower tray component



Saline Tube

- Connects the water membrane lifter to a syringe for hydraulic elevation
- * Syringe : Sold separately, Not part of the kit components



Mallet

- Delivers controlled force to the osteotome handle during bone osteotomy
- Deliver controlled impact at a steady speed, avoiding excessive force
- *Lower tray component

✳Example: Residual bone height of 5 mm

Initial drilling

- Use a drill stopper 1-2 mm shorter than the bone height below the maxillary sinus floor, as measured by CBCT
- Recommended speed: 600 ~ 1,000 rpm

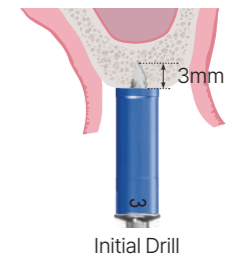

Expansion drilling

- Drill to the same depth as the initial drilling
- Recommended speed: 600 ~ 1,000 rpm



Sinus approach drilling

- Drill up to 1 mm below the sinus floor using a Ø2.8 mm drill
- Verify residual bone with a depth gauge
- If further expansion is required, switch to a different drill while maintaining the same stopper length
- Recommended speed: 600-1,000 rpm

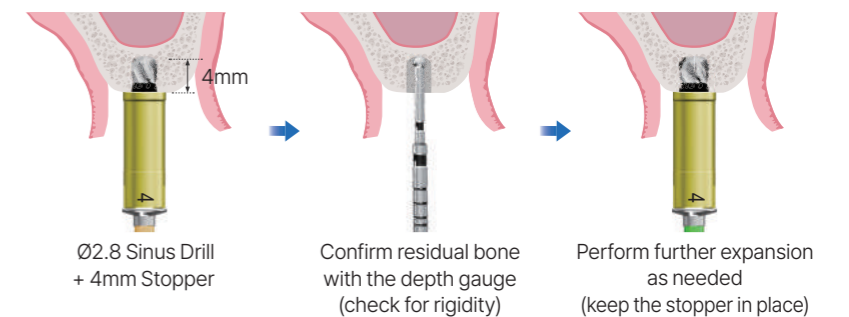

Malleting with osteotome

- Select an osteotome according to the drill diameter
- Choose a stopper matching the residual bone height
- Use a mallet to carefully perform osteotomy of the residual bone

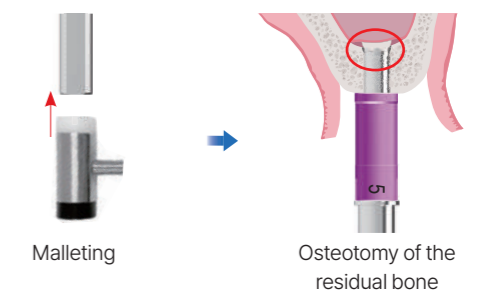

Bone graft and implant placement

- Verify the osteotomy based on bone fracture sound or by using a depth gauge
- Elevate the sinus membrane together with the fixture
- Bone grafting may be performed as needed

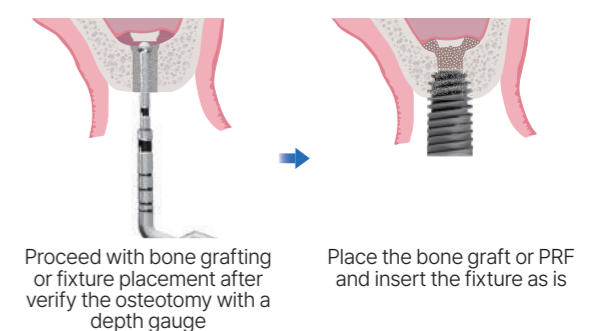

Sinus Kit

Design Features of 4 Key Tools

Surgical Protocol

Additional Lifting for 4mm or higher

Sinus Lift Drill

- key instrument that allows safe and convenient membrane elevation
- Complete the sinus procedure with just drilling and implantation



Half-round Tip

Provides safety on inclined sinus floors and excellent cutting efficiency in bi-cortical bone

Flute & Chip pocket Design

Smoothly pushes bone chips toward the sinus membrane

Depth Control

Built-in stopper ensures precise drilling depth according to residual bone height

Wave ST Osteotome (Patent Pending)

- Minimizes patient discomfort and maximizes procedural convenience
- Requires only two-thirds of the force compared to conventional osteotomes for bone fragmentation

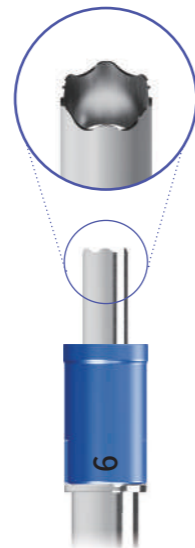

Wave Tip Design

- Reduces impact transmitted to the patient
- Secures fragmented bone for stable vertical elevation
- Rounded, non-sharp edges enhance safety

Stoppers in Varying Lengths

- Allow convenient depth control
- Ensure safe osteotomy

Multi Initial ST Drill & Stopper

- Creating the initial drilling hole or adjust drilling direction with precision
- Special design prevents slipping, even on inclined bone surfaces
- Appropriate stopper use considering residual bone height
- Convenient specification selection with color-coded stopper lengths and clear laser markings

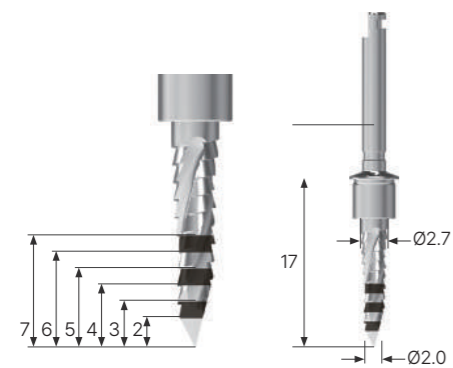

Drilling Length	2	3	4	5	6	7	8	9	10	11	12
Stopper Length	15	14	13	12	11	10	9	8	7	6	5

Sinus Membrane Detach tool

- Designed for safe membrane detachment through the crestal approach
- Its slender, rounded shape ensures safe elevation, even in cases with minimal residual bone



[Capable of unilateral detachment up to 2.7 mm]

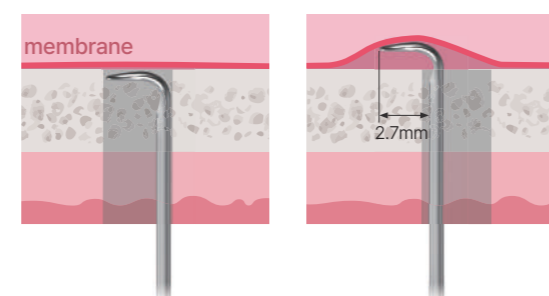

Water Membrane Lifter Designed for clinician's Convenience

- Designed for easy fixation to bone, allowing freehand procedures regardless of whether flap open or flapless
- When elevation of more than 4 mm is required, proceed with the sinus approach drilling as usual, then perform additional elevation according to the following steps

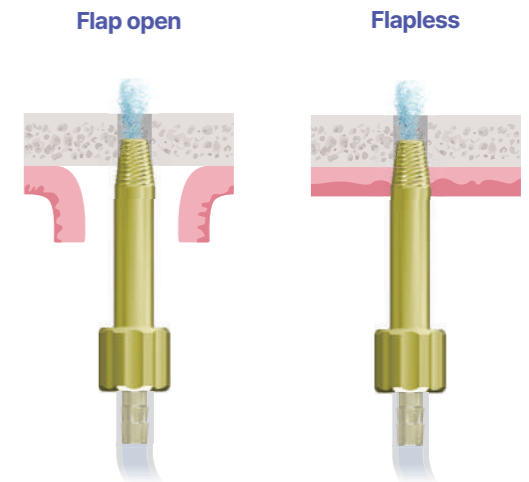

Hydraulic Elevation Tip Selection

- Ø2.8/Ø3.2 are yellow and Ø3.6/Ø4.1 are green
- Choose the tip based on the diameter of the sinus drill

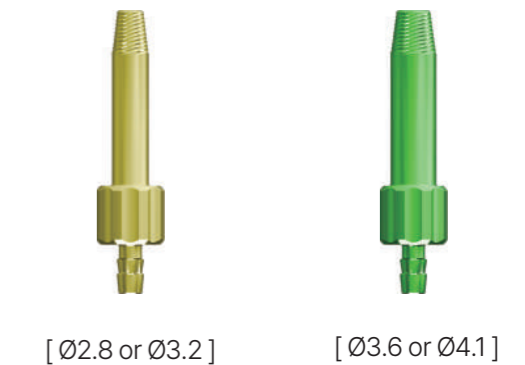

Manual Fixation to Bone

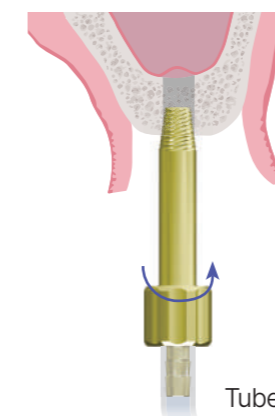

Tube + Syringe

Slow Hydraulic Elevation (freehands)

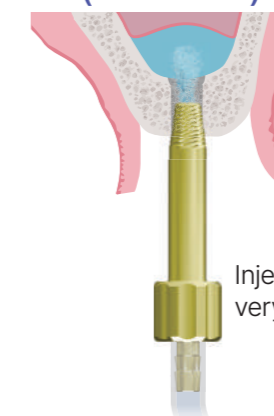

Inject 0.8-1 cc very slowly

Bone Graft and Implant Placement



Elevate the membrane while placing the implant fixture

- Bone grafting is optional
- After placing the bone graft material (space maintenance and osteoconduction), place the fixture